

Lever scroll chuck is specially designed for grinding twist drills and other cutting tools.

Standard accessories:

- 1 operating lever
- 1 set of mounting screws
- 1 set of hard solid jaws

三爪自定心手紧卡盘

标准配件:

- 一个扳手
- 一套安装螺丝
- 一套卡爪

K01 SERIES 3-JAW LEVER SCROLL CHUCKS K01 系列三爪自定心手紧卡盘

FUERDA

尺寸图 Dimensions

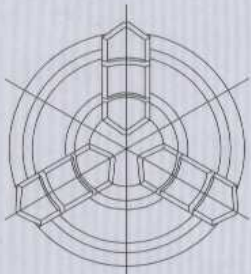

螺纹连接
Thread mtg.

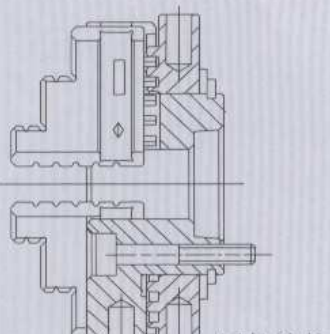
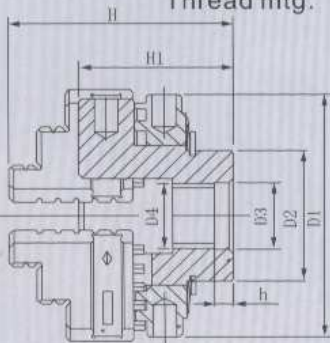

圆柱连接
Cyl. centre mtg.

夹持范围 Clamping Range

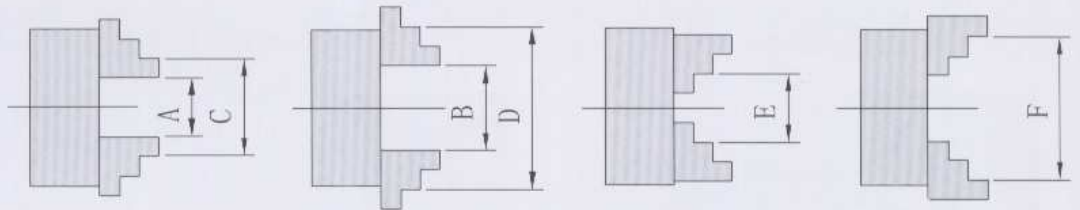

规格表 SPECIFICATIONS

单位/UNIT: mm

卡盘尺寸 Chuck Size	Code No.	D1	D2	D3	D4	h	H	H1
50	K01-50	50	28	15	M12×1 M14×1 SM3/4"×16	4	48	33
65	K01-65	68	28	15	M12×1 M14×1 SM3/4"×16	4	48	33
80	K01-80	84	45	25	3-M5	3	42	30

规格/型号 SPEC./MODEL	夹持范围 Max. Gripping Dia.			最高回转速度 Max. Speed (r.p.m)	最大静夹持力 Max. Gripping Force (kN)	毛重 Gross Weight (Kg)
	正爪 Internal Jaws		反爪 External Jaws			
	A-B	C-D	E-F			
K01-50	1-15	20-48	20-47	9000	7	0.4
K01-65	2-16	25-60	22-55	8200	8	0.7
K01-80	2-18	25-75	22-63	7500	9	1.2