

MATCHLING
33010

TOOL MAKERS VISE

● MCL-A20,25,30,40

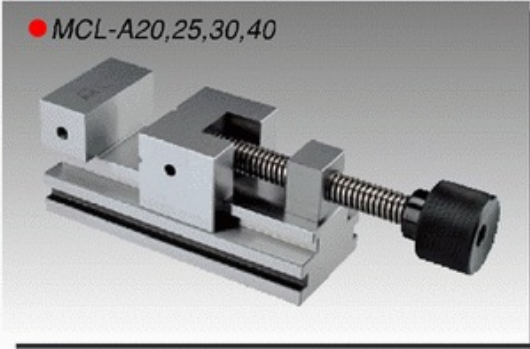

Material SK2
Parallelism Within 0.003mm/100mm
Squareness Within 0.005mm/100mm
Harden treatment up to HRC 58°

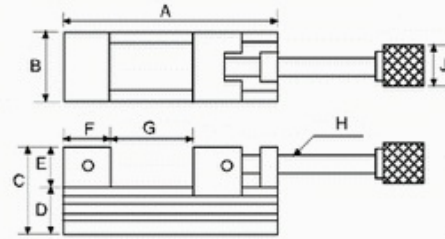

Unit:mm

Order No.	Model	A	B	C	D	E	F	G	H	J	N.W
33010-20	MCL-A20	140	48	55	30	25	25	0- 75	M16	30	2.7kg
33010-25	MCL-A25	160	63	69	39	30	30	0- 85	M16	30	4.6kg
33010-30	MCL-A30	180	73	78	43	35	35	0- 95	M20	40	6.4kg
33010-40	MCL-A40	230	96	92	47	45	40	0-120	M24	40	13 kg

33012

ECONOMIC TOOL MAKER VISE

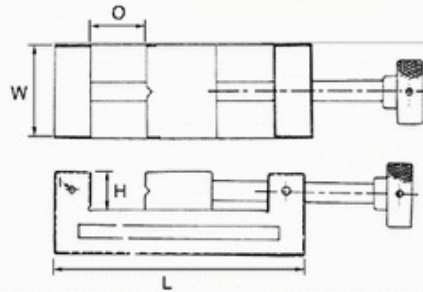
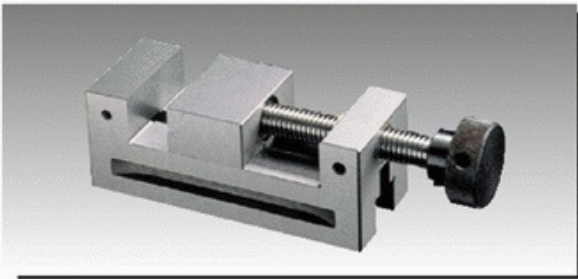

Unit:mm

Order No.	Model	L	W	H	O	HARDEN	N.W.
33012-20	VA20	155	48	25	60	HRC54° -56°	3 kg
33012-25	VA25	176	64	30	75	HRC54° -56°	4 kg
33012-30	VA30	181	74	30	75	HRC54° -56°	6 kg
33012-40	VA40	250	98	38	125	HRC54° -56°	12 kg

33013

ECONOMIC TOOL MAKER VISE

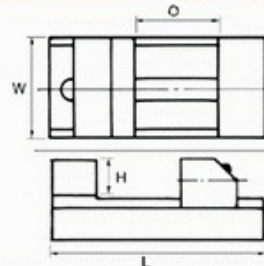
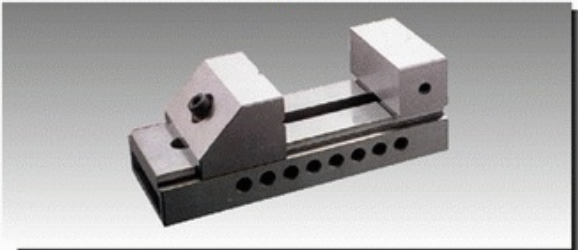

Unit:mm

Order No.	Model	L	W	H	O	HARDEN	N.W.
33013-20	VB20	150	48	30	75	HRC54° -56°	2 kg
33013-25	VB25	170	63	35	90	HRC54° -56°	4 kg
33013-30	VB30	190	73	35	100	HRC54° -56°	4.1 kg
33013-35	VB35	225	88	45	125	HRC54° -56°	7.3 kg
33013-40	VB40	230	98	45	125	HRC54° -56°	10 kg
33013-50	VB50	287	125	50	150	HRC54° -56°	18 kg
33013-60	VB60	330	150	50	200	HRC54° -56°	23 kg