

Model : BS - 2

FEATURES :

The Universal Index Center has been designed to carry out all types of gearcutting, precision dividing and spiral work (except Type BS-0, and BS-1) with greater precision and efficiency than has been possible before. The center face can be tilted from a horizontal position of 90° down to 10° from vertical, and inclinations can be read off a scale graduated in degrees.

The center is built to highest engineering standards and is factory inspected and tested to assure complete satisfaction. The ratio of worm to gear is 1:40

REMARK :

Operation and Service Manual" followed with each of Dividing Head for reference.

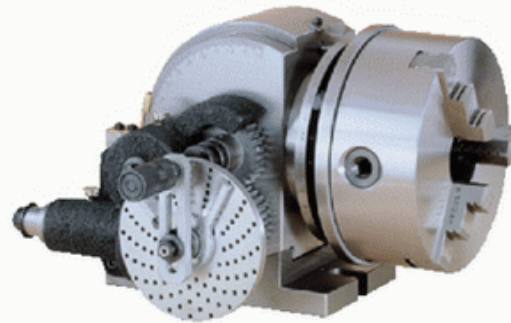
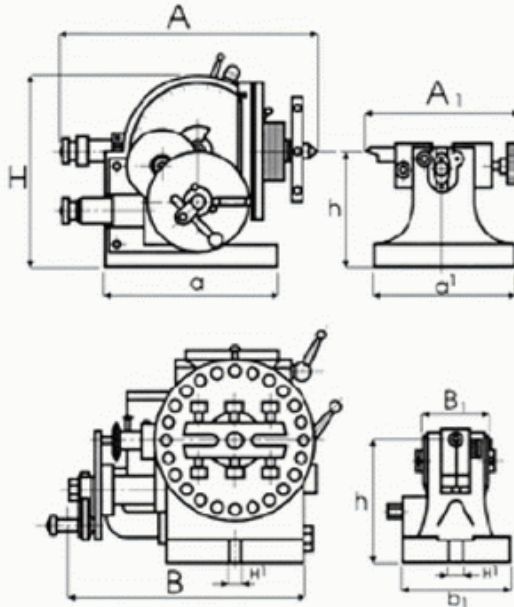

OPTIONAL ACCESSORY :

- 3-Jaw Chuck
- 6" or 7" 3-Jaw Chuck for BS-2.

UNIVERSAL INDEX CENTER B & S NO.2 (HEAD STOCK)

Unit:mm

Model	A	B	H	h	a	b	g	Taper of Center	N.W. (kg)
BS-2	365	272	263	132.7	213	134	16	B&S.No.10	73

UNIVERSAL INDEX CENTER B & S NO.2 (TAIL STOCK)

Unit:mm

Model	A1	B1	H1	h	a1	b1	g1	N.W. (kg)	Measurement m ³
BS-2	205-255	88	139	132.7	175	124	16	Packed with the Dividing Head	

STANDARD ACCESSORIES

Dividing plate A, B, C.

Numbers of holes of dividing plate (worm gear reduction ratio 1:40)

Numbers of hole.	Plate A	15	16	17	18	19	20
	Plate B	21	23	27	29	31	33
	Plate C	37	39	41	43	47	49